

## T22P

Standard Office IP phone

3-Line business IP phone  
with large LCD screen

HD Voice

PoE 3

Headset Port



T22P is the ideal IP business phone to equip the office for reliable, intensive telephone based business without incurring extravagant expense. Productivity driven, this best selling mid range phone is a robust, hard working favourite.

# T22P

## Network Features

SIP v1(RFC2543), v2(RFC3261)  
3 User accounts  
NAT Transverse: STUN mode  
IP Assignment: Static/DHCP/PPPoE  
In-Band DTMF, Out-of-Band DTMF, SIP Info  
Proxy mode and Peer-to-peer SIP link mode  
TFTP/DHCP/PPPoE client  
Telnet/HTTP server  
DNS client  
NAT/DHCP server  
Support VLAN, QoS  
PoE optional

## Voice Features

Wideband Codec: G.722, voice spectrum between 50-7000Hz  
Narrowband Codecs: G.711, G.726, G.723.1/iLBC, G.729AB and GSM  
VAD, CNG, AEC, PLC, AJS, AGC  
Full-duplex hands-free speakerphone

## Telephony Features

Call Hold, Call Waiting, Call Transfer, Call Forward  
Caller ID, Call List, DND, Redial, Flash  
3-way Conference, Speed Dial  
Personal Ring Tone, Voicemail  
Volume Adjustment, Mute, Speakerphone

## IP PBX System Integration

Dial Plan, Dial-now, Paging  
Downloadable enterprise phonebook  
Call Park, Call Pickup, Distinctive Ringtone  
Auto-answer, intercom

## Config, Upgrade and Usage

Language Customization Support  
Firmware Upgrade: TFTP/Console/Auto-provision  
Auto-provision: TR069 Optional  
Direct IP call without SIP proxy  
Dial number via SIP server  
Dial URL via SIP server

## Security

Secure RTP  
Digest authentication using MD5/MD5-  
sess  
Secure configuration file via AES  
encryption

## Physical Features

TI Titan Chipset  
LCD: 132x64 with blue backlight  
3 programmable keys, 4 text-sensitive  
keys  
23 hard keys, 2 indication LEDs  
Headset port: RJ9  
Network Interface: 2xRJ45 10/100M  
ports  
Dimension: 275 x 220 x 105 mm  
Net Weight: 1.22 kg  
Power adapter: Input: AC 100~240V  
Output: DC 5V/1A  
Operating humidity: 10~95%  
Storage temperature: up to 60 C

## Package Features

Qty per Carton: 10  
Carton Weight: 13.3 Kgs  
Carton Dims: 565 x 570 x 255 mm

## Certifications

WEEE

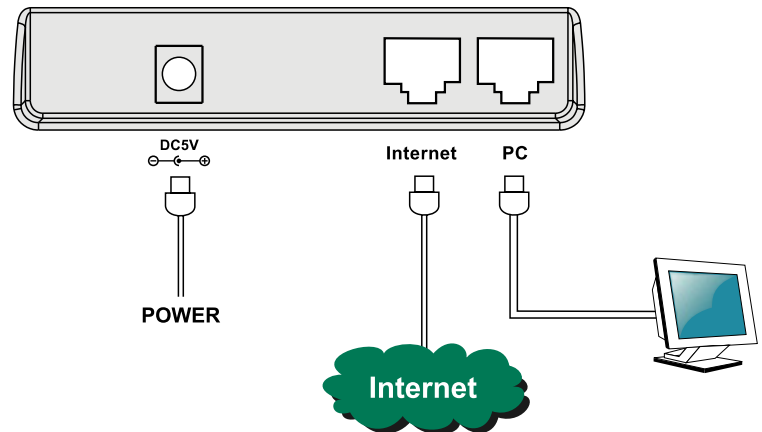

**Yealink**  
EASY VoIP